

RECOMMENDED PCB LAYOUT
GENERAL TOLERANCE ±0.05

070	17.00	19.30	20.70
060	14.50	16.80	18.20
040	9.50	11.80	13.20
CKT	DIM A	DIM B	DIM C

NOTES:

- MATERIAL:
 - HOUSING: SOMIKASUPER LCP E6808L-BLACK, HIGH TEMP.,UL94V-0
 - CONTACT: PHOSPHOR BRONZE
- FINISH:

CONTACT:

C: 50u" MIN. NICKEL PLATING OVERALL
GOLD PLATING 15u" MIN. ON CONTACT
AND G/F PLATING ON SOLDER.
- SPEC. PLS. REFER TO PS-51088-XXXX-XXX
- PACKAGE PLS. REFER TO 51091-XXXCR-XX
- PART NUMBER

51091-XXX X X- 001

NO OF CKT:

PACKING:

0: TAPE & REEL

PLATING:

1:G/F ON CONTACT AND SOLDER
C:15u" GOLD ON CONTACT

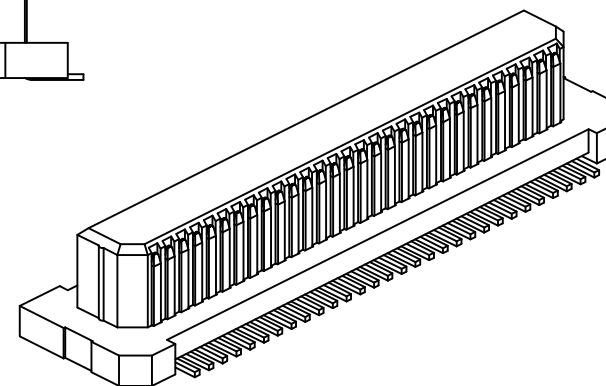
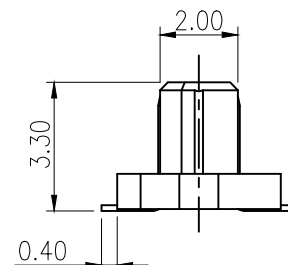

QUALITY SYMBOLS	DRAWN BY	DATE	ACES ELECTRONICS		
MAJOR Ⓢ	TSO I CHIAO	20/01/22			
CRITICAL Ⓢ	CHECKED BY	DATE	TITLE		
GENERAL TOLERANCES (UNLESS SPECIFIED)	Chen, Chun Yuan	20/01/22			0.50mm PITCH BOARD TO BOARD CONN (PLUG)
X. ±0.5	APPROVED BY	DATE	UNITS	SIZE	
.X ±0.25	Wang, chun sheng	20/01/22	mm	A4	51091-XXXXX-XXX
.XX ±0.15			SCALE	SHEET NO.	REV
.XXX ±0.1			2 : 1	1 OF 1	A
ANGLES ±2°					PART NO.
					SEE NOTES